



Installation Instructions

717993

**2009-2022* DODGE RAM 1500 TRUCKS
WITH 4.7L & 5.7L HEMI ENGINES**
2- or 4-WHEEL DRIVE, 140" and 149" WHEELBASE
with single or dual factory tailpipes

***2019-24 "Classic Body" Only**

See "Applications" tab on the product web page for specific applications.

ITEM	PART NO.	DESCRIPTION	QTY.
1	26520M	INLET PIPE ASSY	1
2	72288-Z	FLOWFX MUFFLER	1
3	86726M	TAILPIPE ASSEMBLY	1
4	MC300SB	CLAMP, STAINLESS, 3"	2
5	MC250SB	CLAMP, STAINLESS, 2-1/2"	2
6	HA572	BRACKET, UNIVERSAL, STEEL & RUBBER	1
7	HW225	SCREW, THREAD CUTTING, 5/16-18 x 3/4"	2

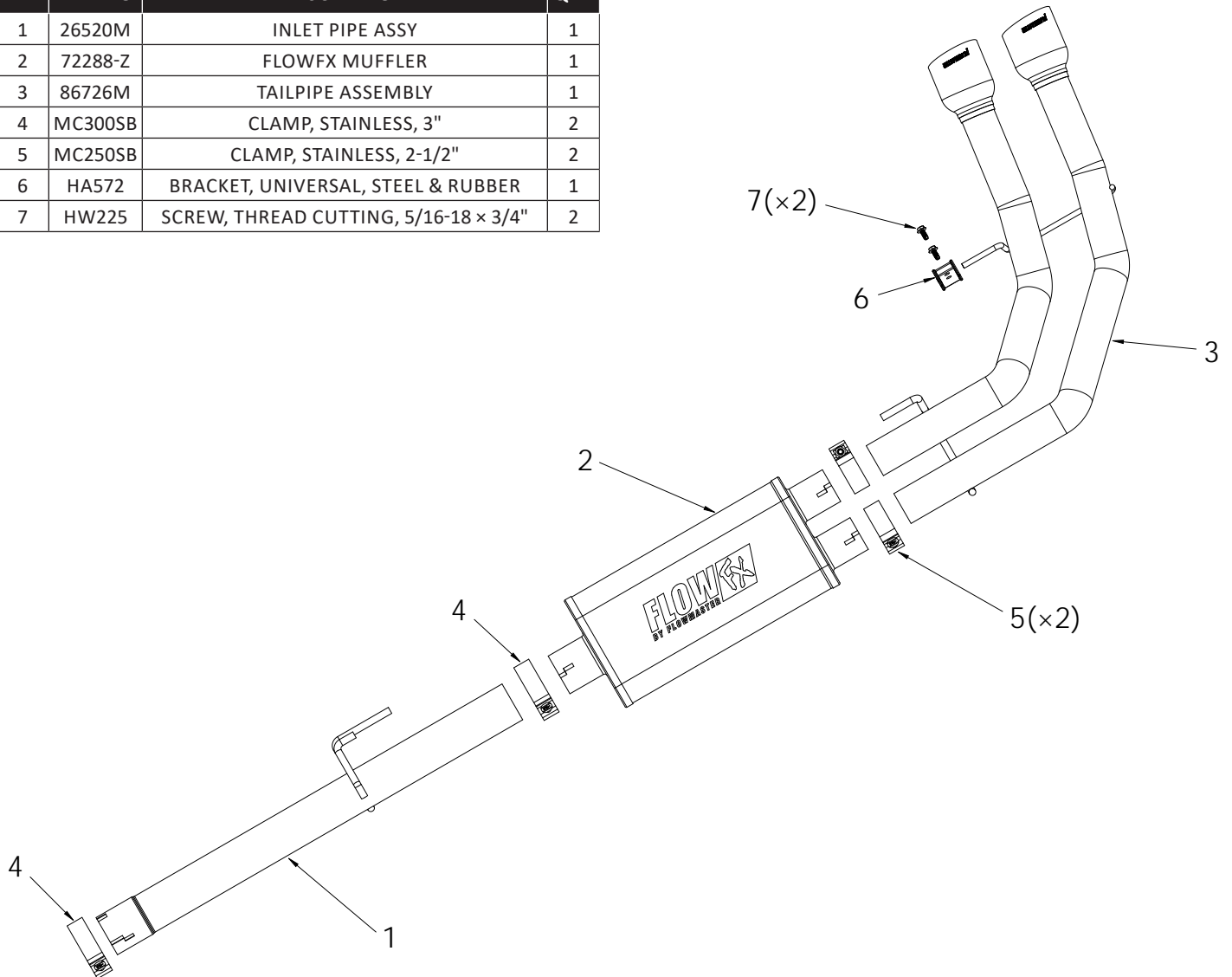

NOTES

- Installation requires moderate mechanical skill. If this job is beyond your abilities, seek the services of a qualified technician.
- If you do not understand any part of these instructions, please call Flowmaster Technical Support at (866) 464-6553 for assistance.
- Use stands to support exhaust system components, both while removing the stock system, and during installation.
- Apply penetrating oil generously to clamps, pipes, and hanger rods to ease disassembly.

REVIEW THE INSTRUCTIONS & VERIFY THE KIT CONTENTS

Take a moment to read and understand these instructions before installing your Flowmaster FlowFX exhaust kit.



Use the parts drawing and list to verify your kit's contents. In the unlikely event that any parts are missing, please contact Flowmaster Technical Support for replacements.

REMOVE THE FACTORY EXHAUST SYSTEM

WARNINGS

- **AVOID BURNS!** Exhaust systems get extremely hot. Allow the vehicle to cool down fully before starting work.
- **AVOID SERIOUS INJURY OR DEATH BY CRUSHING!** Never work under a vehicle that is supported by jacks.

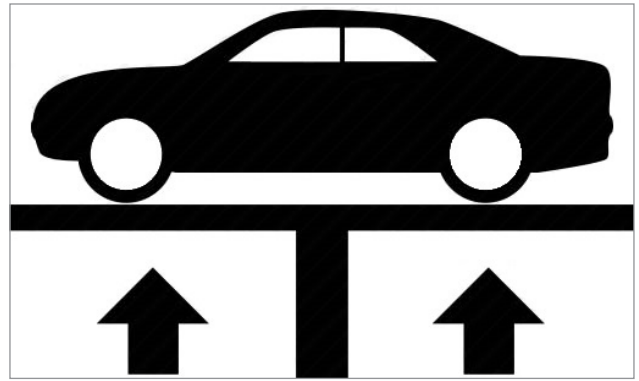

1. **Raise the vehicle** to working height on a lift. If you do not have a lift, securely support the vehicle on jack stands.

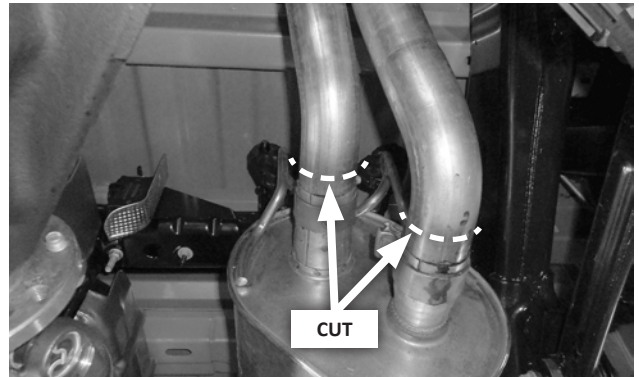

2. **Cut the tailpipe(s) off** just behind the muffler clamp(s).

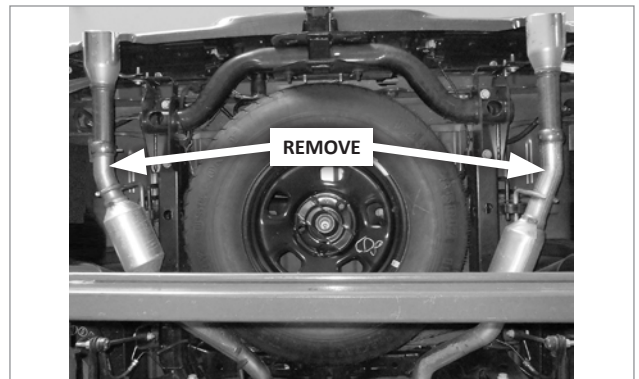

3. **Release the tailpipe hanger rods from their rubber isolators, and remove the tailpipe(s) from the vehicle.**

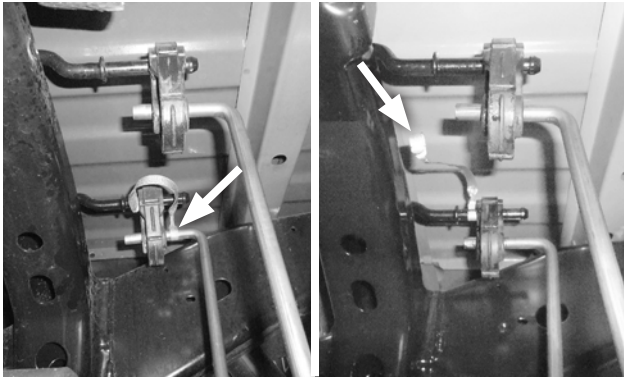

4. If you find a bonding strap between the frame and muffler hangers during disassembly, unclip the muffler-end of the strap.

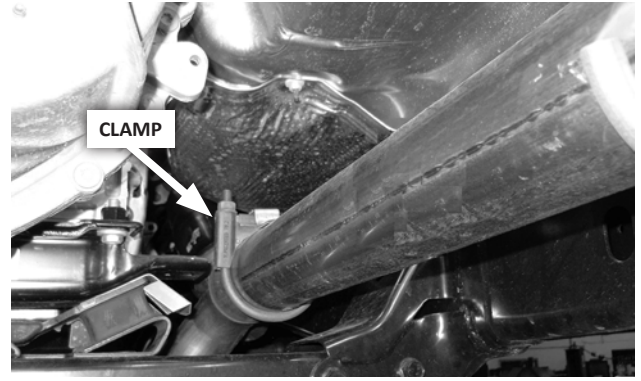

NOTE: The clamp may need to be cut, and the inlet pipe will likely need to be heated, to remove the pipe.

7. Remove the clamp from the slip-on connection at the front of the inlet pipe. Then remove the inlet pipe.

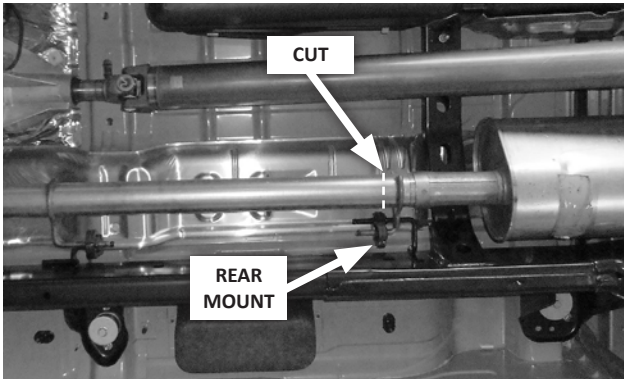

5. Cut the inlet pipe off just forward of its rear hanger rod (so that the rod remains with the muffler). Remove the muffler by pulling the hanger rods out of their isolators.

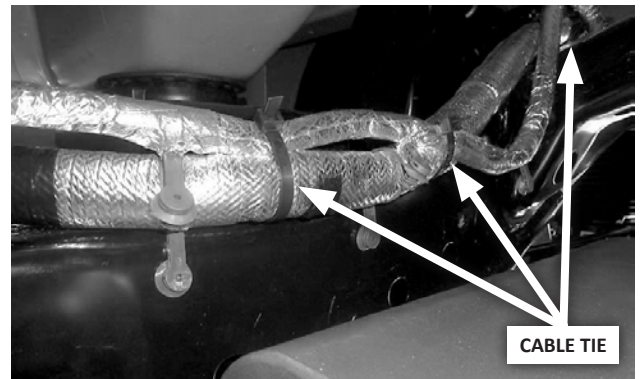
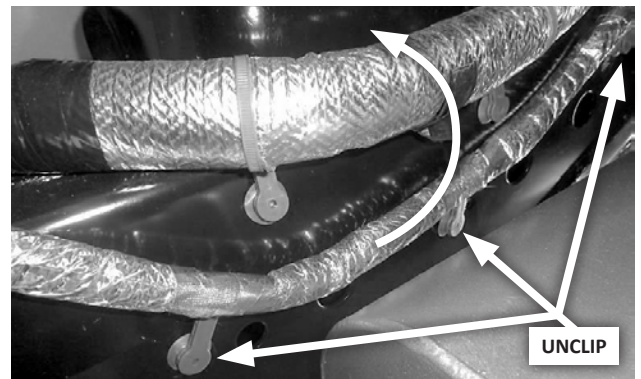

8. If there is a wire loom routed along the inner face of the right frame near the muffler's location, unclip the harness from the frame, then cable tie it to top of the frame (or to the wire loom already on top of the frame).



6. Pull the inlet pipe's front isolator mount off of the frame and pipe hanger rods.

INSTALL YOUR FLOWMASTER EXHAUST SYSTEM



9. Remove the nuts from the four clamps, apply anti-seize compound to the bolt threads, and re-install the nuts.

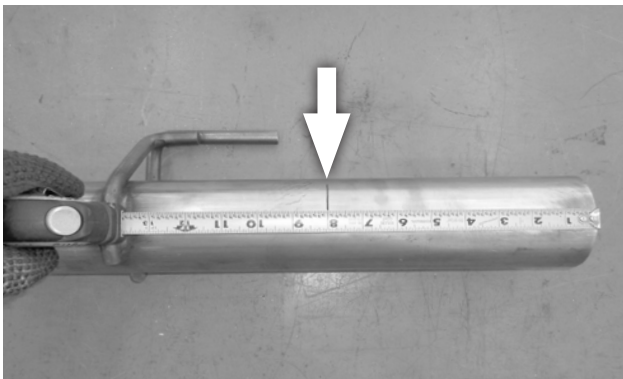

CAB	BED	WHEELBASE	REMOVE 8"
Regular	8 ft	140 in	YES
Quad	6 ft - 4 in		
Crew	5 ft - 7 in		
Crew	6 ft - 4 in	149 in	NO

10. If applicable to your truck's configuration, cut 8" off of the muffler-end of inlet pipe (1):

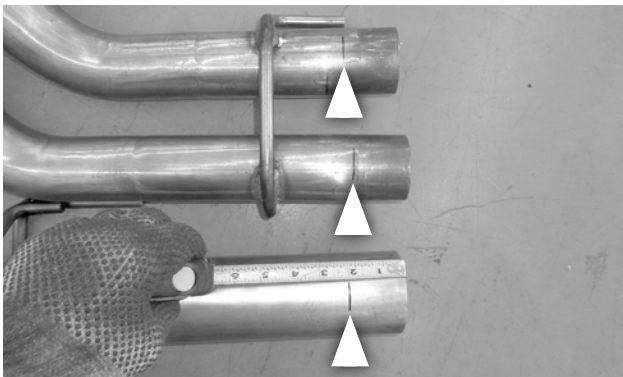

11. Each pipe must be inserted approximately 2" into the muffler. Mark each pipe 2" from its end to ensure proper insertion during assembly.

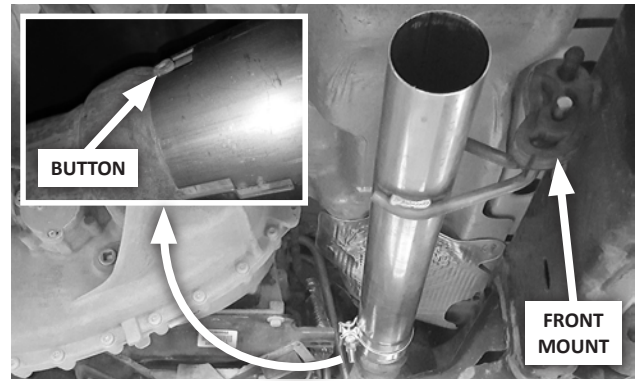

12. Slip one 3" clamp (4) over the front of the inlet pipe. Align the notch at the front of the pipe with the button on the stock Y-pipe, and slide the inlet pipe fully onto the Y-pipe. Install the front isolator mount on the pipe and frame hanger rods. Slide the clamp over the end of the pipe, and snug it slightly (just enough to allow final adjustment later).



13. Slip the second 3" clamp (4) over the muffler (2) inlet. Then install the muffler on the rear end of the inlet pipe and support it with a stand. Verify 2" of insertion, and snug the clamp.



14. Install universal bracket (6) onto the rear hanger rod on tailpipe assembly (3), with the flat facing away from the tailpipe tips.

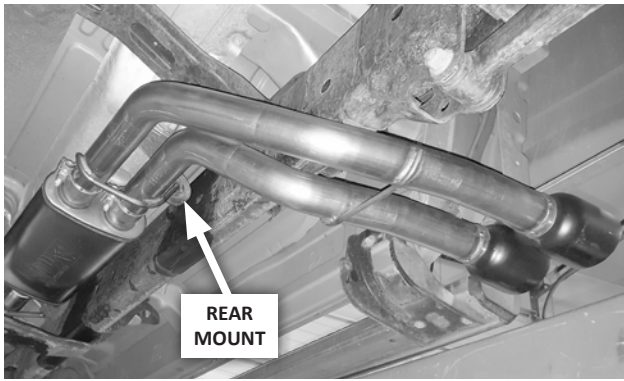

15. Slip two 2-1/2" clamps (5) over the muffer outlets. Insert the tailpipe assembly's hanger rod in the rear isolator mount, insert both pipes 2" into the muffer, and snug the clamps.

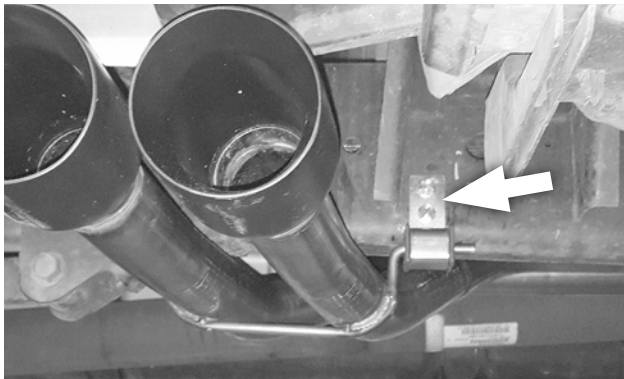

16. Adjust the tailpipe assembly so that the pipes clear the frame, and the tips are set at the desired distance from the body. Lay the bracket flat against the truck's frame, then mark its hole locations on the frame. Move the bracket aside, drill a 1/4" hole at each mark, and secure the bracket to the frame with the two thread-cutting screws (7).



17. Adjust all components to give 1/2" to 3/4" clearance (a finger's width) around them, and allowing for suspension travel and vibration. When you are satisfied with the system's clearance and fit, tighten the four clamps. If you disconnected any frame-to-exhaust bonding wires at Step 4, reconnect them now (relocate if required).

18. Recommended: Tack weld (approx. 1") the slip-fit connections for added security, then paint each weld with a coat of high-temp spray paint to protect against corrosion.



Congratulations, the installation of your Flowmaster FlowFX performance exhaust system is complete!

KEEP THESE INSTRUCTIONS FOR FUTURE REFERENCE

Flowmaster maintains a highly-trained technical service department to answer your technical questions, provide additional product information and offer various recommendations.



FLOWMASTER TECHNICAL SUPPORT: (866) 464-6553